

Deployment Planning Guide



Deployment Planning Checklist:

- ✓ **Step 1:** Select your assets (equipment) for remote monitoring
- ✓ **Step 2:** Determine test points for sensor installation
- ✓ **Step 3:** Determine number of gateways required
- ✓ **Step 4:** Confirm availability of wireless connectivity

Simple steps for program success:

A little planning and preparation will help you smoothly install the 3561 FC Vibration Sensor. Quickly and easily plan the deployment of your wireless vibration program by following the steps in this guide. Learn how to select your assets, sensor locations, gateway locations and network connectivity options. Perform a site survey with the Worksheet A & B: Asset Information Table (Appendix) and sample site map (Appendix) to assist in gathering information needed for deployment planning, ordering the right hardware and installing sensors. Print out the Appendix for your site survey.

3561 FC Vibration Sensor

The Fluke 3561 FC Vibration Sensor allows maintenance teams to add remote, continuous vibration monitoring to assets, maximizing equipment uptime and minimizing unnecessary routes. With a frequency range of 10 - 1,000 hertz (Hz), the 3561 FC detects and notifies users of critical faults such as imbalance, misalignment, looseness and bearing wear, providing early warning of potential equipment failure.

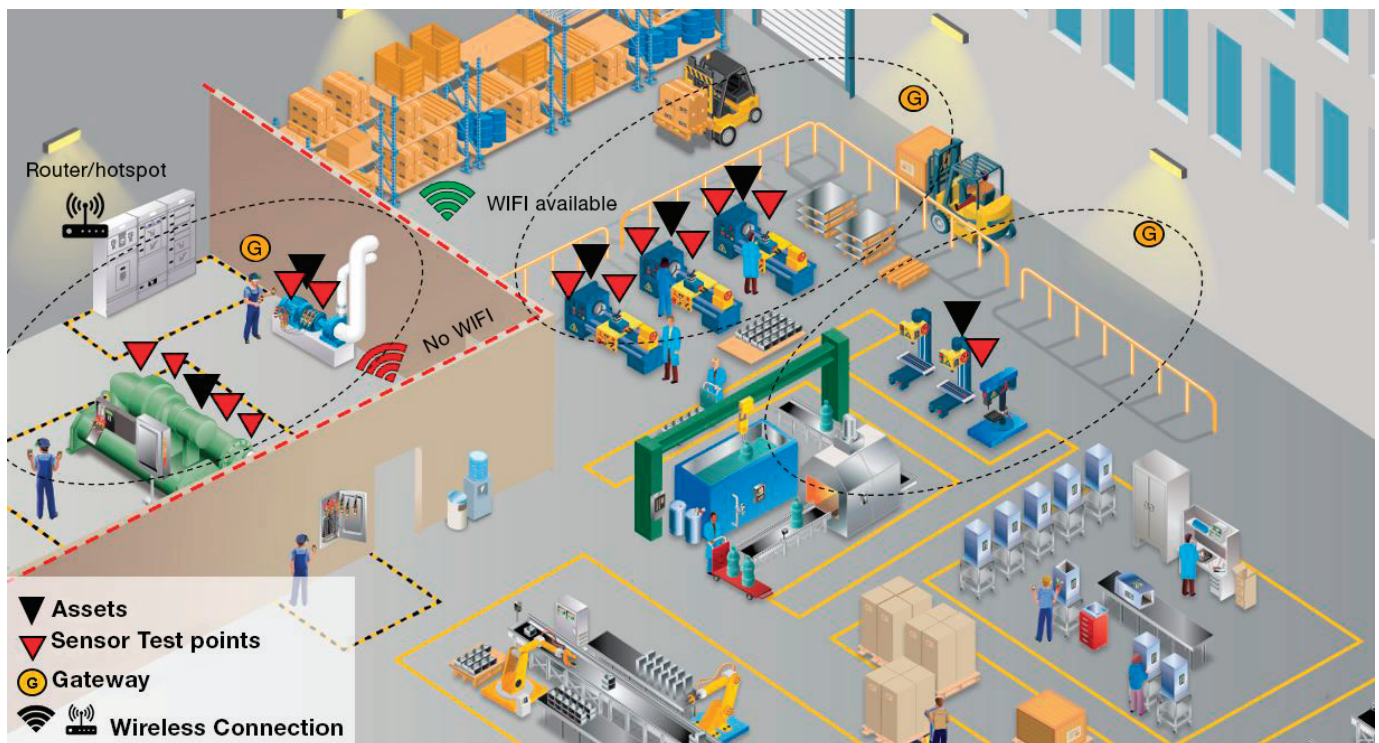

Step 1

Select your assets (equipment) for remote monitoring

A. Asset selection

Survey the site where you plan to deploy the vibration sensors and select the assets to monitor. We recommend using this sensor as a screening tool. The sensors notify teams when faults start developing, enabling them to take further diagnosis and analysis actions.

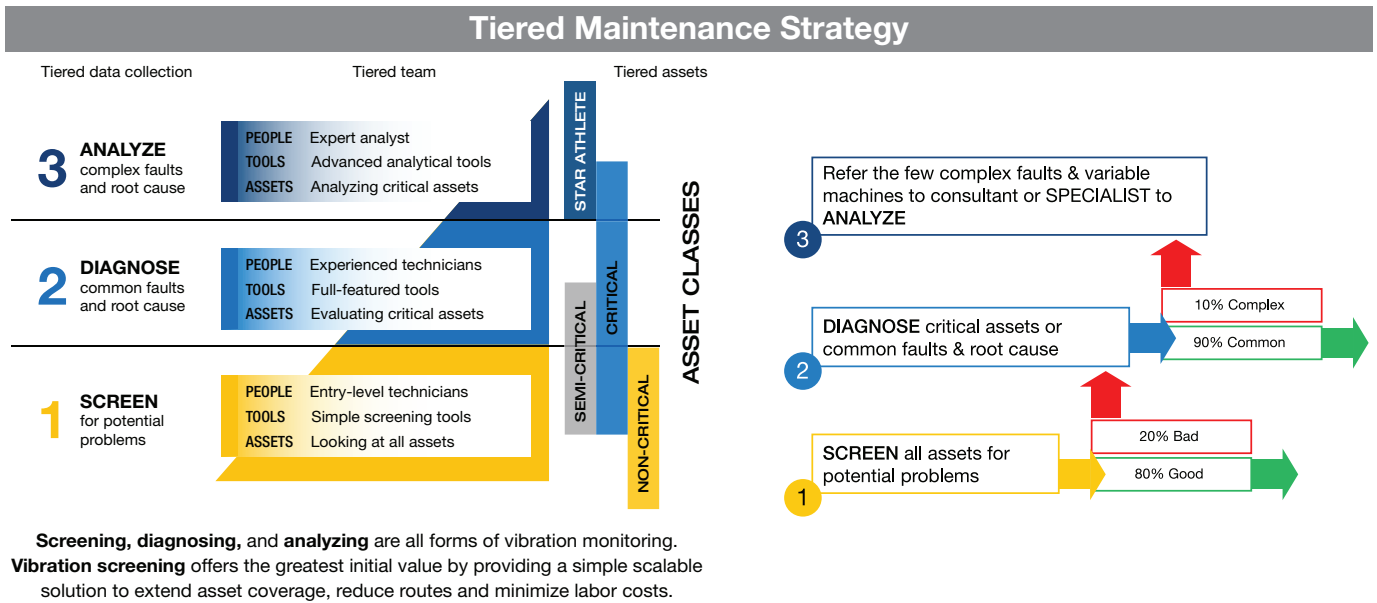

B. Determine machine category

This is a critical piece of information required to screen the health of your assets and generate alarms when faults develop.

Follow the simple questions below to select the proper machine category from available flow paths:

- Select the machine category by the driven component (the motor is included with the driven component)
- Select the machine category that is the closest match to your machine (it is OK if it's not an exact match)

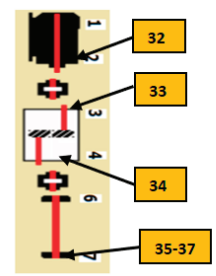
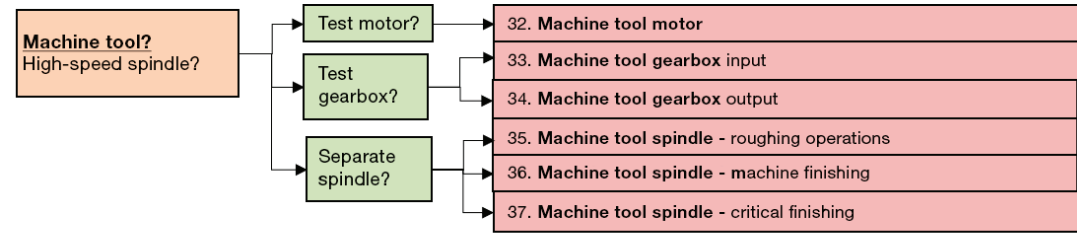
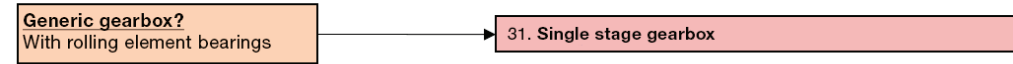
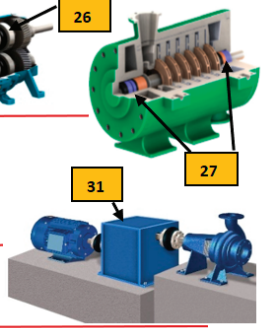
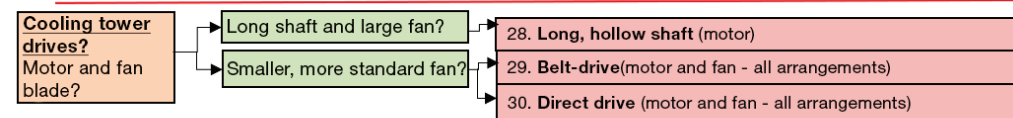
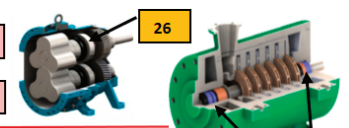
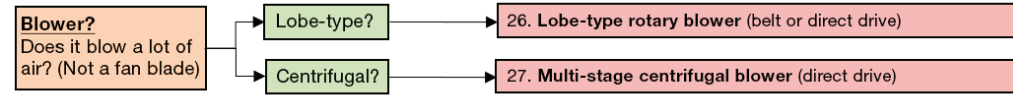
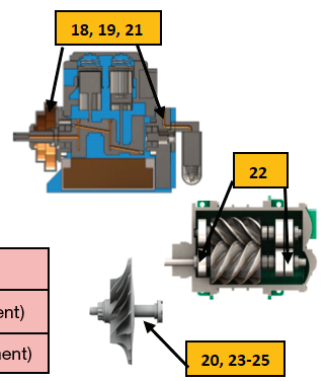
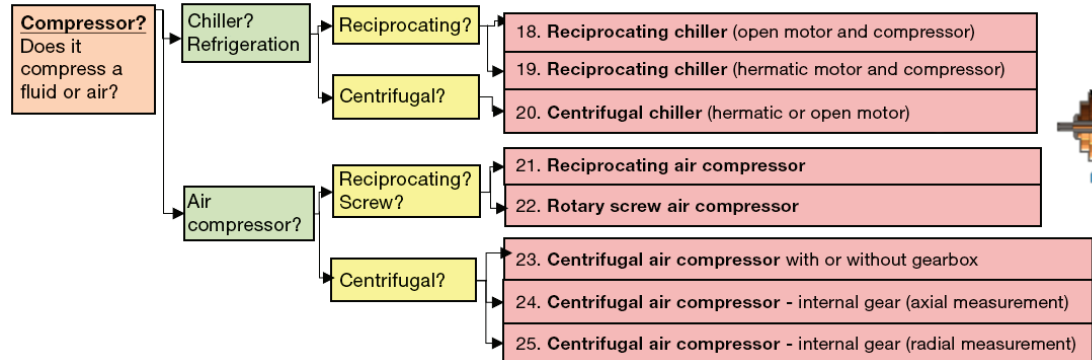
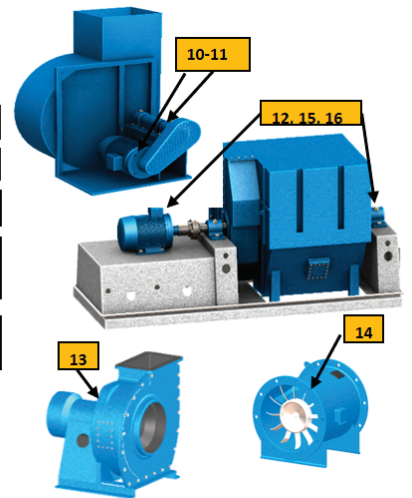
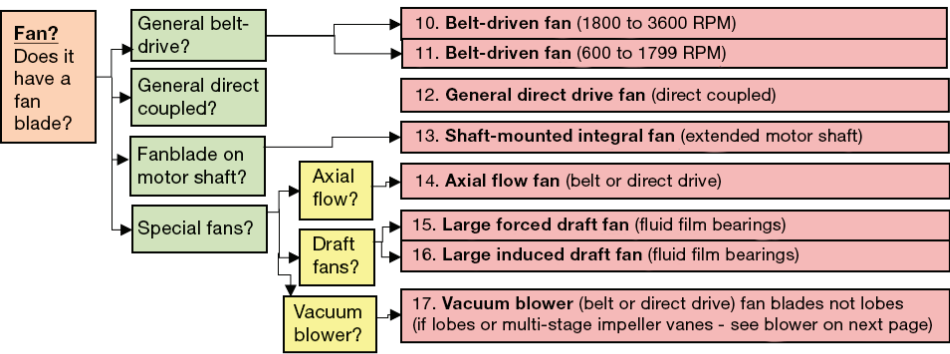
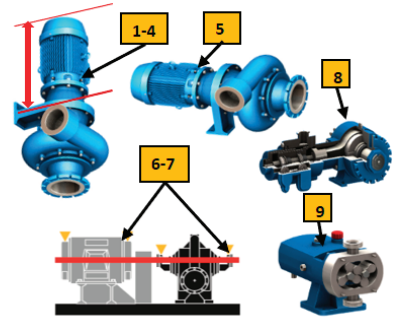
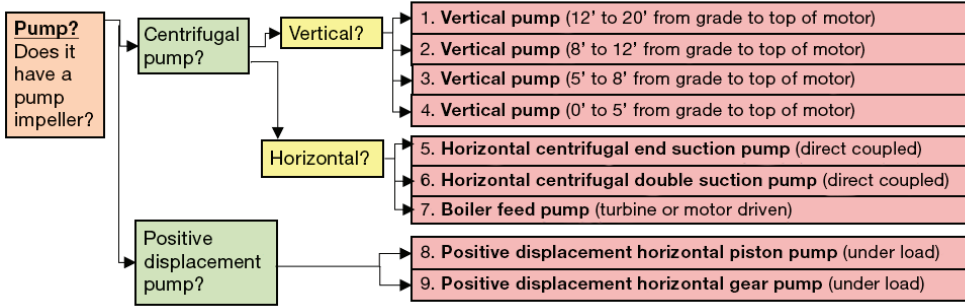

C. Record asset information

With the information collected, complete the “Asset” section of the Worksheet B: Asset Information Table in the Appendix. Use the sample information shown in Worksheet A for your reference.

Step 2

Determine test points for sensor installation

Next, determine how many test points are required on each monitored machine for sensor installation.

Machine basics for rotating machines

For vibration monitoring, we can simplify a machine to one or two shafts with two bearings each, something connecting the shafts and something hanging off the end. Look at your machine and identify the shaft(s), bearings, coupling and driven component. We recommend one sensor per bearing.

How to select locations for mounting sensors?

A. Machine survey

Break your machine down to basic parts:

- Shaft(s)
- Bearings, coupling, belt or gearbox
- Driven element (pump, fan, compressor, blower, etc.)

Find the configuration of your machine to determine bearing location for sensor installation.

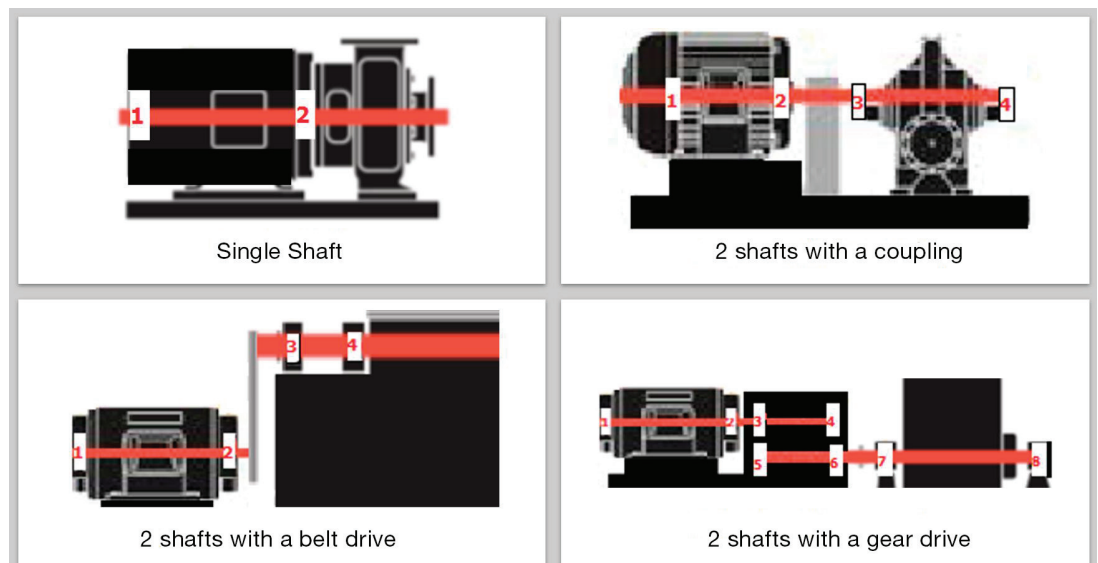

B. Sensor location identification

Determining the bearing location depends on the driving element (motor) type and the driven element (such as a pump).

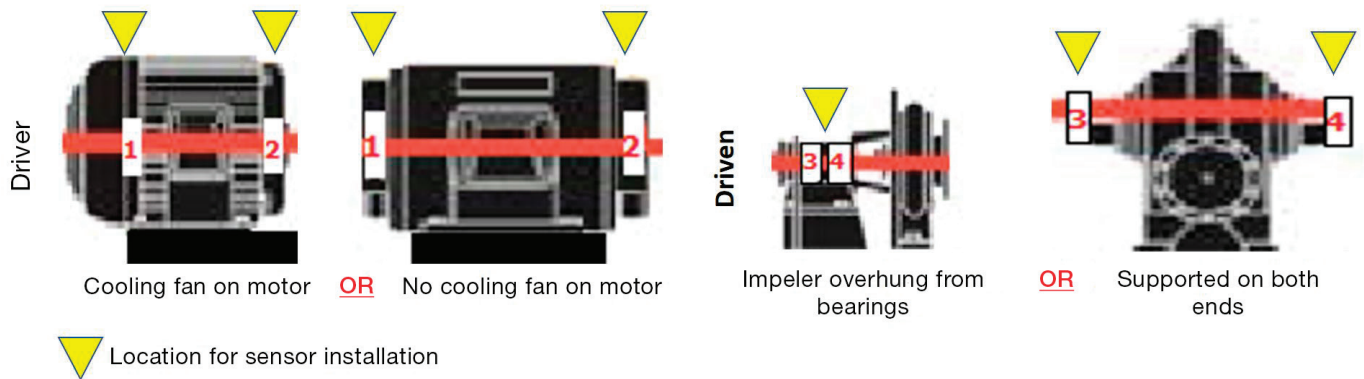

C. Determine number of sensors depending on size

Vibration transmits about 36 inches (1 meter) before it is lost through the machine. There is no need to measure every bearing on small machines. Transmission path should be as short and solid as possible— from rotating shaft, to bearing, to bearing housing and into the sensor.

D. Record sensor information

Using the above information, determine the test points for sensor installation and fill in Worksheet B: Asset Information Table in Appendix. Use the sample information shown in Worksheet A for your reference.

Step 3

Determine number of gateways required

The maximum distance between the sensors and gateway is 25 meters (line of sight).

Step 4

Confirm availability of wireless connectivity

The Gateway requires wireless connectivity to stream vibration data to the cloud. Ensure availability of network connectivity in the installation location.

Option 1: Use Wi-Fi connectivity (2.4 GHz) at the installation location.

For vibration monitoring, we can simplify a machine to one or two shafts with two bearings each, something connecting the shafts and something hanging off the end. Look at your machine and identify the shaft(s), bearings, coupling and driven component. We recommend one sensor per bearing.

1. Obtain the Wi-Fi network name and password.

2. Make sure your network complies with these requirements:

- 2.4 GHz connectivity
- WLAN Standards: 802.11 g/n GHz
- Upload speed: 1 Mbps (Sustained)
- Internet HTTP Proxy: Disabled
- Supported Authentication Protocols: WPA

OR

Option 2: Use mobile router/hotspot

If the installation area does not have wireless coverage, consider using a wireless hotspot or router for network connectivity. For example: Verizon Jetpack MiFi, Cradlepoint, etc.

On completion of the above 4 steps, the Asset Information Table is complete for a successful installation. For the in-app setup and installation of sensors, refer to Getting Started Manual for the 3561 FC Vibration Sensor found at www.fluke.com/quickstart.

Appendix

Sitemap

For the area where you plan to install, refer to a sitemap to pictorially plan the deployment. If you don't have one, create a simple hand draw site map. This lets you plan gateway and network connectivity to ensure that there is optimal coverage and seamless data streaming.

Sample sitemap with deployment planning

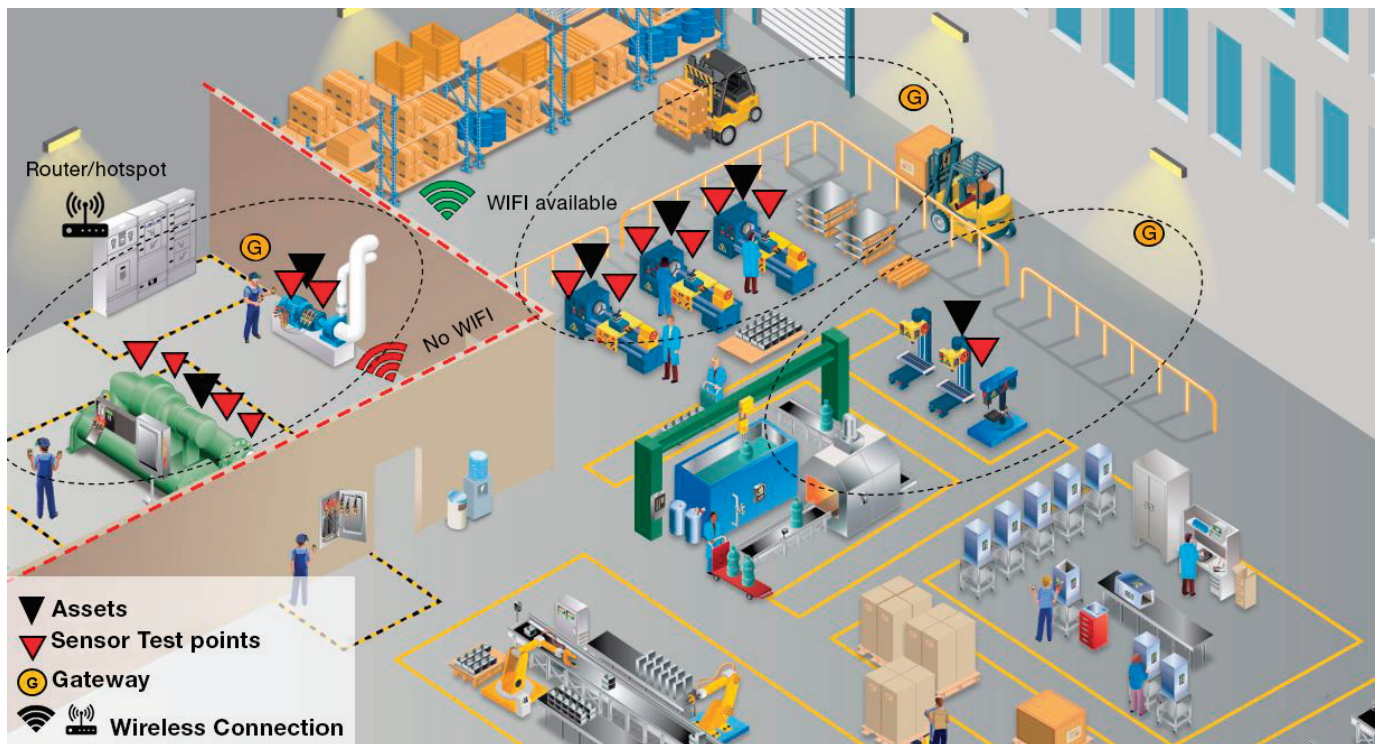

Do's and Don'ts

- ✓ Mount the sensor on solid metal anywhere on or near the bearings but not on thin covers
- ✓ If the machine is small, mount a sensor on one motor bearing and one pump bearing
- ✗ Do not mount sensor on motor winding box – bearings only
- ✗ Do not mount sensor in the middle of motor – bearings only
- ✗ Do not mount sensor on pump casing – bearings only (flow noise)
- ✗ Do not mount sensor on thin cooling fan cover – solid metal only
- ✗ Do not mount sensor on thin cooling fins – solid metal only
- ✗ Do not mount sensor on a coupling or belt guard
- ✗ Do not mount sensor on seals – bearings only

WORKSHEET A - Asset Information Table - Sample

Table 1: Asset Information Table - Sample

Asset Information			Test Point Information		3. Hardware needed			
Asset Group (Location)	Asset (Machine name)	Select Machine Category (1 of 37)	Test Point - Sensor (Bearing location)	Notes about Test Point Location - obstructions/issues	Sensors	Gateway	Hotspot /Router	Sensor ID
Boiler Room	Horizontal Water Pump 1	5. Horizontal centrifugal end suction pump	Motor Bearing 2	Top of motor bearing, no fins	1	1	1	12345
Boiler Room	Horizontal Water Pump 1	5. Horizontal centrifugal end suction pump	Pump Bearing 3	Top of pump bearing, center	1			ABCDE
Boiler Room	Horizontal Water Pump 2	5. Horizontal centrifugal end suction pump	Motor Bearing 2	Top of motor bearing, no fins	1			67890
Boiler Room	Horizontal Water Pump 2	5. Horizontal centrifugal end suction pump	Pump Bearing 3	Top of pump bearing, center	1			FGHI2
Boiler Room	Horizontal Water Pump 3	5. Horizontal centrifugal end suction pump	Motor Bearing 2	Top of motor bearing, no fins	1			JKLMN
Boiler Room	Horizontal Water Pump 3	5. Horizontal centrifugal end suction pump	Pump Bearing 3	Top of pump bearing, center	1			OPQRS
Boiler Room	Horizontal Water Pump 4	5. Horizontal centrifugal end suction pump	Motor Bearing 2	Top of motor bearing, no fins	1			TUVWX
Boiler Room	Horizontal Water Pump 4	31. Single stage gearbox	Gearbox Bearing 3	Top of gearbox, motor input	1			12345
Boiler Room	Horizontal Water Pump 4	5. Horizontal centrifugal end suction pump	Pump Bearing 5	Top of pump bearing, center	1			ABCDE
Boiler Room	Vertical Water Pump 1	5. Horizontal centrifugal end suction pump	Motor Bearing 2	Side of lower motor bearing	1	1		67890
Boiler Room	Vertical Water Pump 2	5. Horizontal centrifugal end suction pump	Motor Bearing 2	Side of lower motor bearing	1			FTH45
Boiler Room	Blower 1	13. Shaft-mounted integral fan	Motor Bearing 2	Top of motor bearing, near fan	1			J3H29
Boiler Room	Blower 2	13. Shaft-mounted integral fan	Motor Bearing 2	Top of motor bearing, near fan	1			K3K23
Boiler Room	Air Compressor 1	21. Reciprocating air compressor	Motor Bearing 2	Top of motor bearing, near belt	1			LJ549
Boiler Room	Air Compressor 2	21. Reciprocating air compressor	Compressor Bearing 3	Top of compressor bearing, near belt	1			23889
Boiler Room	Fan 1	11. Belt-driven fan (600-1799 RPM)	Motor Bearing 2	Top of motor bearing, near belt	1			3JK69
Boiler Room	Fan 1	11. Belt-driven fan (600-1799 RPM)	Fan Bearing 3	Top of fan bearing, near belt	1			PJDS0
Boiler Room	Fan 1	11. Belt-driven fan (600-1799 RPM)	Fan Bearing 4	Top of fan bearing, near fan	1			989Y7
Boiler Room	Fan 2	11. Belt-driven fan (600-1799 RPM)	Motor Bearing 2	Top of motor bearing, near belt	1			9SYDU
Boiler Room	Fan 2	11. Belt-driven fan (600-1799 RPM)	Fan Bearing 3	Top of fan bearing, near belt	1			90930
Boiler Room	Fan 2	11. Belt-driven fan (600-1799 RPM)	Fan Bearing 4	Top of fan bearing, near fan	1			D09D9
Boiler Room	Fan 3	12. General direct drive fan (direct coupled)	Motor Bearing 1	Top of motor bearing, behind fan cover	1	1		23I23
Boiler Room	Fan 3	12. General direct drive fan (direct coupled)	Motor Bearing 2	Top of motor bearing, coupling end	1			32ND0
Boiler Room	Fan 3	12. General direct drive fan (direct coupled)	Fan Bearing 3	Top of fan bearing, coupling end	1			67890
Boiler Room	Fan 3	12. General direct drive fan (direct coupled)	Fan Bearing 4	Top of fan bearing, free end	1			WE0IS
Fan Room	Duct Fan 1	14. Axial flow fan (belt or direct drive)	Motor Bearing 2	Top of motor bearing, fan end	1	1	1	19S29
Fan Room	Duct Fan 2	14. Axial flow fan (belt or direct drive)	Motor Bearing 2	Top of motor bearing, fan end	1			12KL3
Fan Room	Duct Fan 3	14. Axial flow fan (belt or direct drive)	Motor Bearing 2	Top of motor bearing, fan end	1			TUVWX
Fan Room	Fan 4	12. General direct drive fan (direct coupled)	Motor Bearing 1	Top of motor bearing, behind fan cover	1	1		12345
Fan Room	Fan 4	12. General direct drive fan (direct coupled)	Motor Bearing 2	Top of motor bearing, coupling end	1			ABCDE
Fan Room	Fan 4	12. General direct drive fan (direct coupled)	Fan Bearing 3	Top of fan bearing, coupling end	1			78906
Fan Room	Fan 4	12. General direct drive fan (direct coupled)	Fan Bearing 4	Top of fan bearing, free end	1			09DSK
					32	5	2	

WORKSHEET B - Asset Information Table - For use

Table 1: Asset Information Table - For use

Asset Information			Test Point Information		3. Hardware needed			
Asset Group (Location)	Asset (Machine name)	Select Machine Category (1 of 37)	Test Point - Sensor (Bearing location)	Notes about Test Point Location - obstructions/issues	Sensors	Gateway	Hotspot /Router	Sensor ID
					0	0	0	

Fluke Corporation
 PO Box 9090, Everett, WA 98206 U.S.A.
For more information call:
 In the U.S.A. 856-810-2700
 In Europe +353 507 9741
 In UK +44 117 205 0408
 Email: support@accelix.com
 Web access: <http://www.accelix.com>

©2020 Fluke Corporation. 04/2020 6011956d-en

**Modification of this document is not permitted
 without written permission from Fluke Corporation.**